

Method for the determination of spectral responsivity of digital solar irradiance sensors

David Hinken^{*,1}, Sebastian Denke¹, Karsten Bothe¹
and Rolf Brendel^{1,2}

¹Institute for Solar Energy Research in Hamelin, Emmerthal, GERMANY

²Institute for Solid State Physics, Leibniz Universität Hannover, Hannover, GERMANY

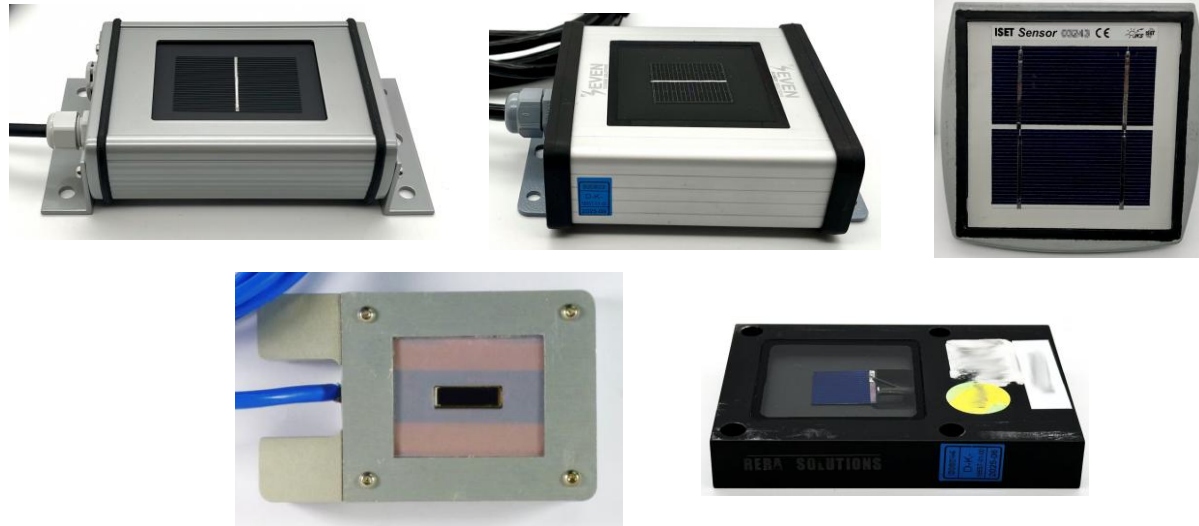
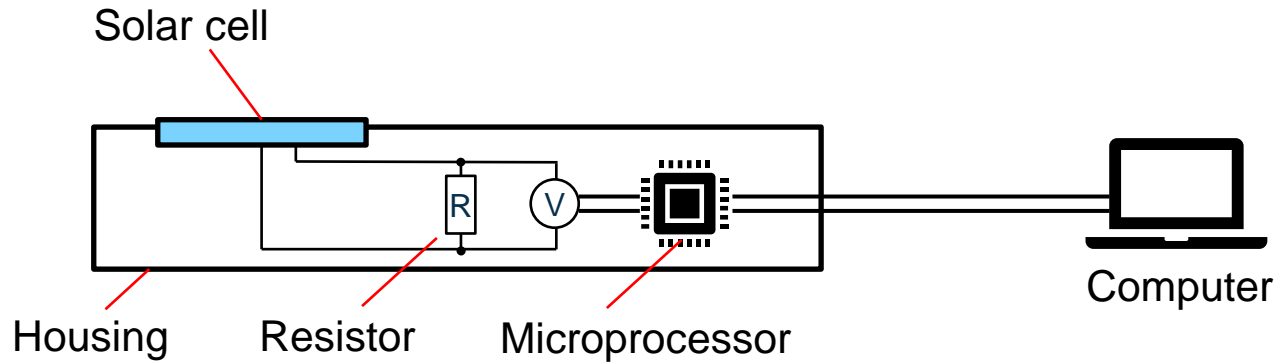

- Typical structure:
 1. Solar cell with shunt resistor
 2. Analog-digital conversion with microprocessor (also provides digital interface)
- Microprocessor converts voltage V (in mV) to irradiance G_{dig} (in W/m^2) using a **calibration factor**
- Different types of solar irradiance sensors available, many with a Modbus interface
- Calibration of these sensors required!

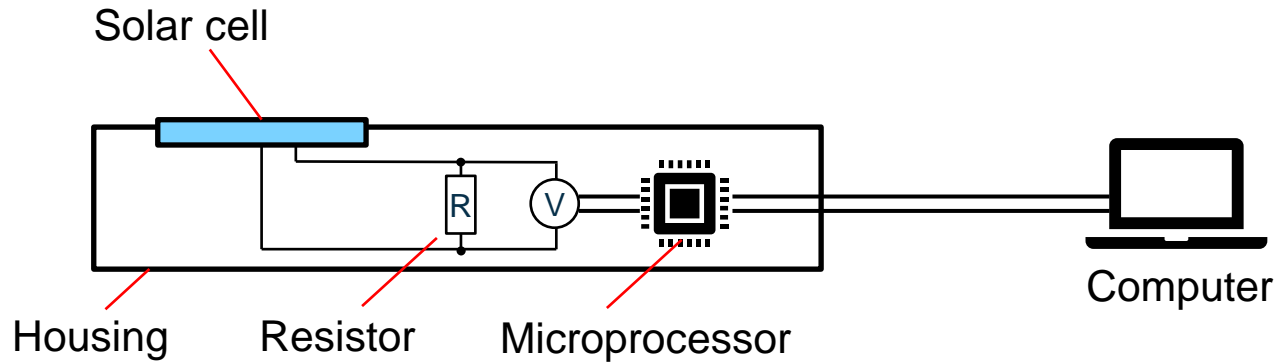

- PV system monitoring standard IEC 61724-1 demands regular calibration of irradiance sensors
- Calibration requirements:
 - **Fulfillment of IEC 60904-2**
 - Reference spectrum IEC 60904-3 (→ AM1.5G)
 - Resolution $< 1 \text{ W/m}^2$
 - Measurement uncertainty $\leq 3\%$



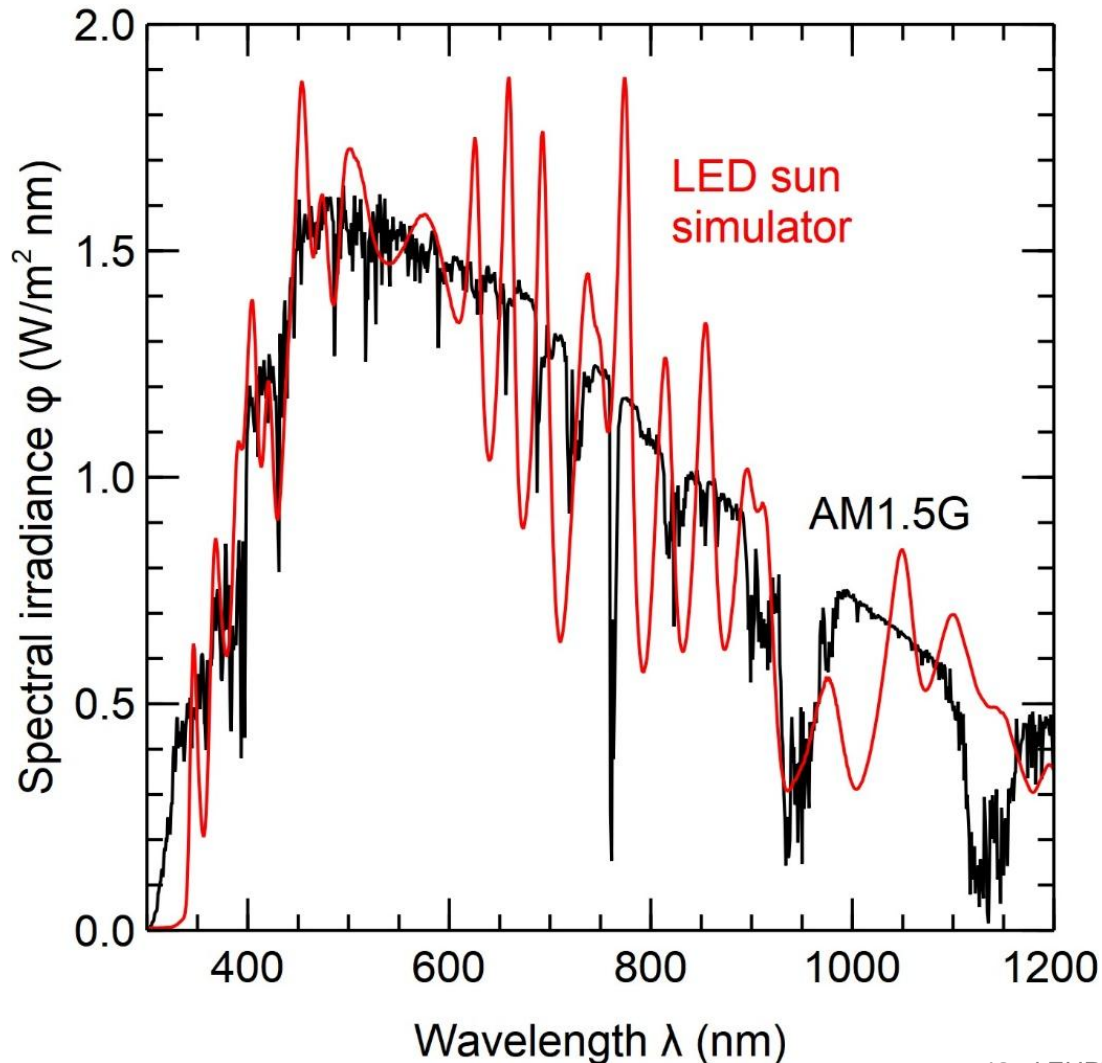

- **IEC 60904-2:** The spectral responsivity (SR/EQE) of each device has to be measured.
- Background: Tabulated reference spectrum cannot be exactly reproduced within a sun simulator
- Calculation of **spectral mismatch factor** requires determination of the spectral responsivity (SR_{smp1})

$$MM = \frac{\int d\lambda \varphi_{\text{ref}}(\lambda) SR_{\text{ref}}(\lambda) \int d\lambda \varphi_{\text{meas}}(\lambda) SR_{\text{smp1}}(\lambda)}{\int d\lambda \varphi_{\text{meas}}(\lambda) SR_{\text{ref}}(\lambda) \int d\lambda \varphi_{\text{ref}}(\lambda) SR_{\text{smp1}}(\lambda)}$$

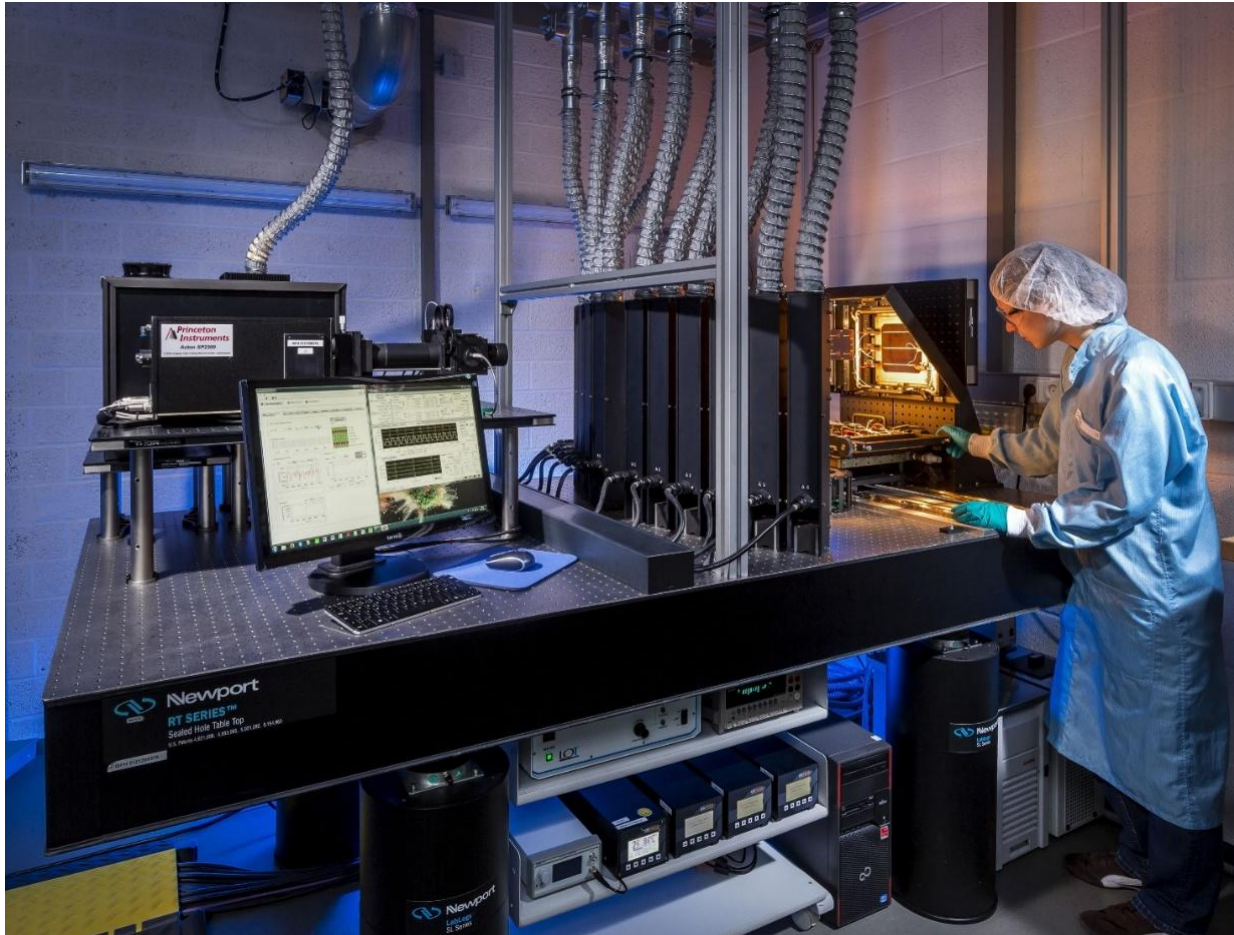

DSR/SR measurement facility at ISFH CalTeC

- **IEC60904-2:** The spectral responsivity (SR/EQE) of each device has to be measured.
- Traditional DSR/SR requires **current as measurand** and does not work with digital units
- Only option: Open sensor, disconnect electronics and shunt resistor, add a direct wire connection to solar cell
- Not feasible for customer sensors → We need something new!

Use LED sun simulator for *SR* determination



Close-up picture of LED array



- Continuous spectrum produced by several LEDs of different color (350 nm to 1200 nm)
- Homogenization optics overlap all LED outputs on the measurement field
- **Idea:** Use spectral variations to determine the spectral responsivity

Method 1: „Single-LED“

Green LEDs on

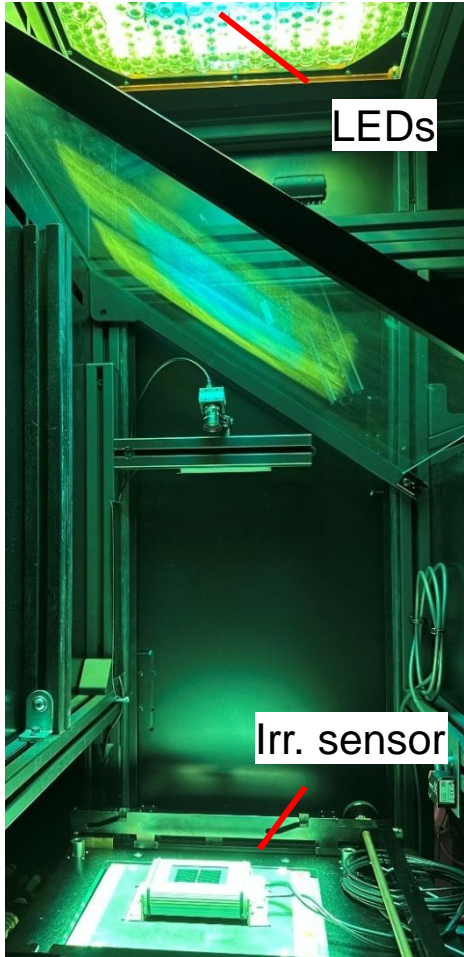

Red LEDs on

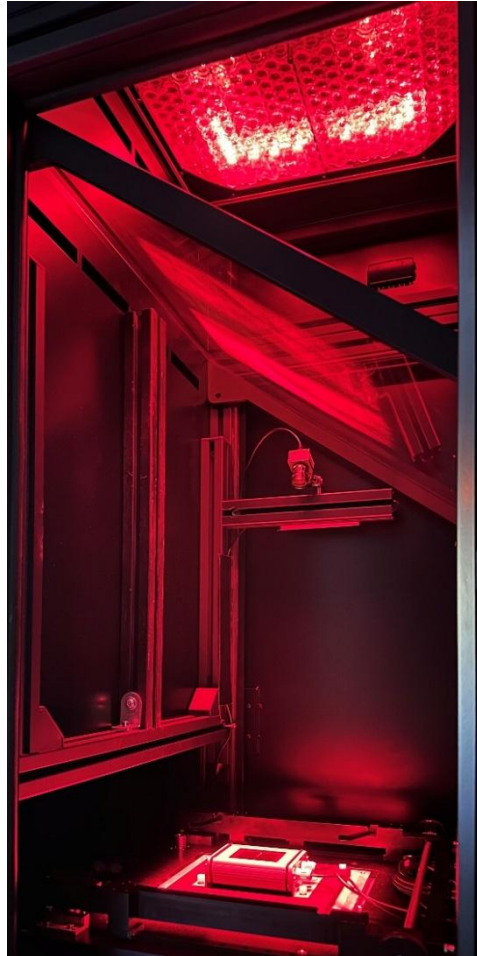

IV measurement facility during SR_{dig} determination

- Single-LED uses one LED channel after the other. For each channel:
 1. Measure short-circuit current I_{scref} of a calibrated solar cell
 2. Get irradiance G_{dig} (W/m²) of sensor (digital)
 3. Calculate spectral responsivity:
$$SR_{\text{dig}} = SR_{\text{ref}} / I_{\text{scref}} \cdot P_{\text{dig}}$$
- SR_{dig} is digital spectral responsivity, quantity is dimensionless

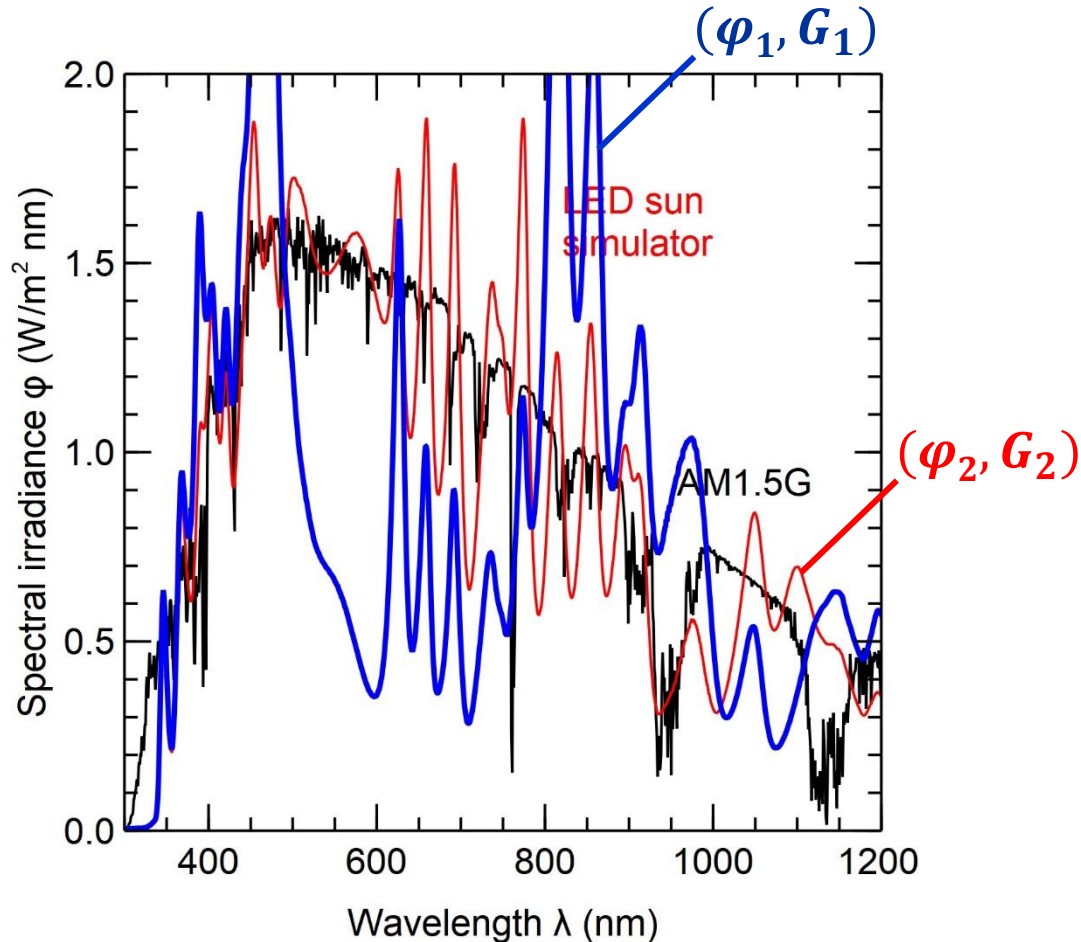

- Multi-SR [1] uses all channels at the same time but with variations:

1. Measure resulting spectra $\phi_i(\lambda)$ with a calibrated spectrometer
2. Get digital output G_{dig} (W/m²) of sensor
3. Utilize equation

$$G_i = \int d\lambda \phi_i SR_{\text{dig}}$$

and a least-square regression to determine SR_{dig}

- We use 50 different broadband spectra

[1] Hinken et al. (2023), Sol. RRL, 7: 2300240.

<https://doi.org/10.1002/solr.202300240>

Testing on two solar irradiance sensors

Sensor 1: Si-RS485TC-T-MB
(IMT Technology)



Sensor 2: 3S-IS with Modbus RTU
(Seven Sensor)



- Testing with two solar irradiance sensors
- Apply both methods

Resulting curves of both methods

Sensor 1: Si-RS485TC-T-MB
(IMT Technology)

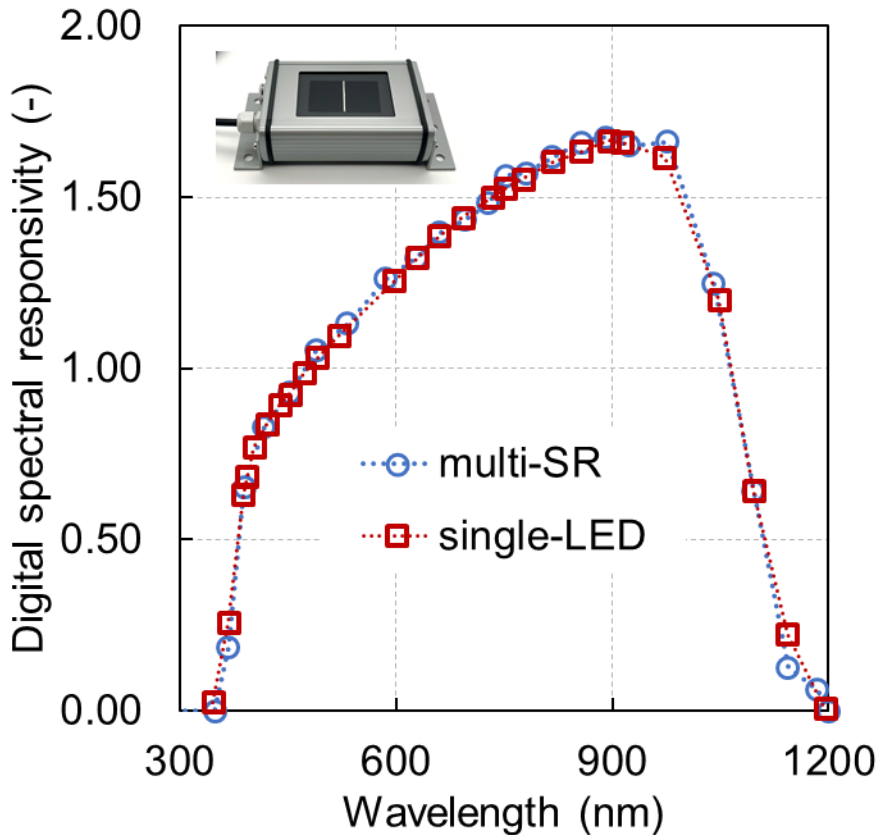

Sensor 2: 3S-IS with Modbus RTU
(Seven Sensor)

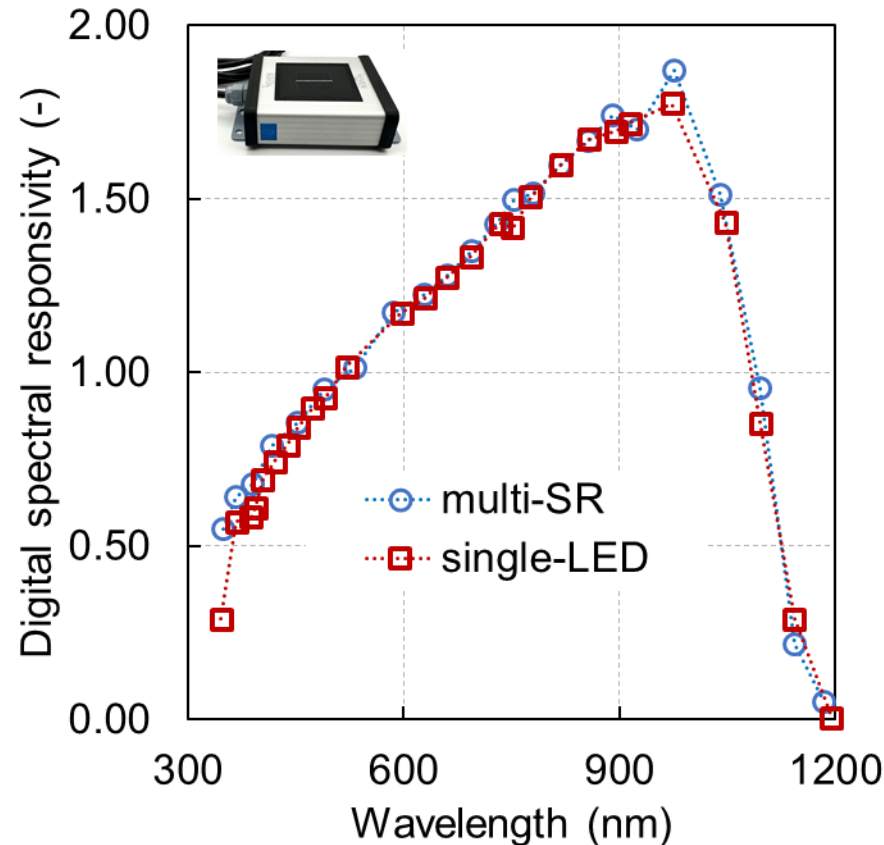

- Curves of both methods are consistent and have expected shape
- Validation with reference method still required

Comparison with DSR/SR measurement facility

Sensor 1: Si-RS485TC-T-MB
(IMT Technology)

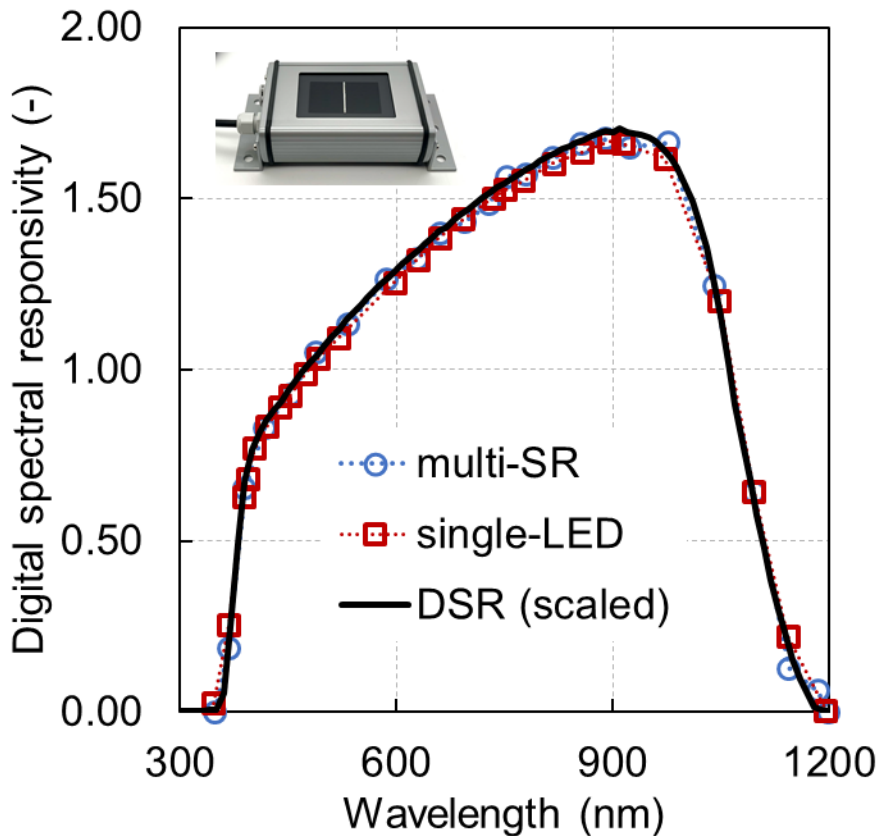

Sensor 2: 3S-IS with Modbus RTU
(Seven Sensor)

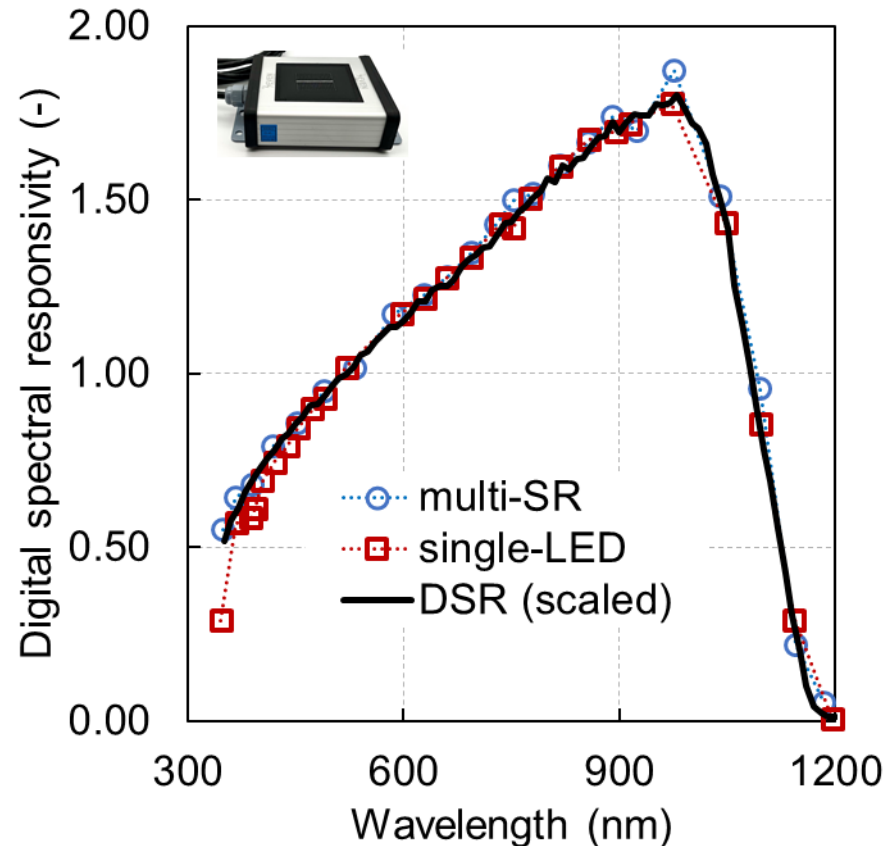

- We opened sensors, removed electronics and shunt and attached direct wire
- Consistent to curve from reference method (solid black line)

Comparison of spectral mismatch factors

Sensor 1: Si-RS485TC-T-MB
(IMT Technology)



	MM	Dev.
single-LED	1.0030	0.00%
multi-SR	1.0038	0.08%
DSR/SR	1.0030	

Sensor 2: 3S-IS with Modbus RTU
(Seven Sensor)



	MM	Dev.
single-LED	1.0029	0.12%
multi-SR	1.0018	0.01%
DSR/SR	1.0017	

- Calculation of spectral mismatch factor (MM) using:
 1. Class A++ sun simulator spectrum
 2. WPVS reference solar cell
- Max. deviation in MM factor to reference method (DSR/SR) is 0.12%

$$MM = \frac{\int d\lambda \varphi_{\text{ref}}(\lambda) SR_{\text{ref}}(\lambda) \int d\lambda \varphi_{\text{meas}}(\lambda) SR_{\text{dig}}(\lambda)}{\int d\lambda \varphi_{\text{meas}}(\lambda) SR_{\text{ref}}(\lambda) \int d\lambda \varphi_{\text{ref}}(\lambda) SR_{\text{dig}}(\lambda)}$$

Comparison table

	Single-LED	Multi-SR	DSR/SR (with modified sensor)
Directly applicable to digital irradiance sensors	Yes	Yes	No
Reference	Calibrated solar cell	Calibrated spectrometer	Calibrated solar cell
Measurement time	5 minutes	5 minutes	1 hour
Can be integrated in IV measurement facility?	Yes	Yes	No, separate facility required
Technical complexity?	Low	Low	High (→ lock-in technique required)
Components commercially available?	Yes	Yes	No (→ transimpedance-amplifier)
Wavelength resolution	Low, LEDs with narrow spectrum required	Higher	Highest
Working point (excess charge carrier density)	Extremely low or bias-variations required	Same working conditions	Bias-variations required

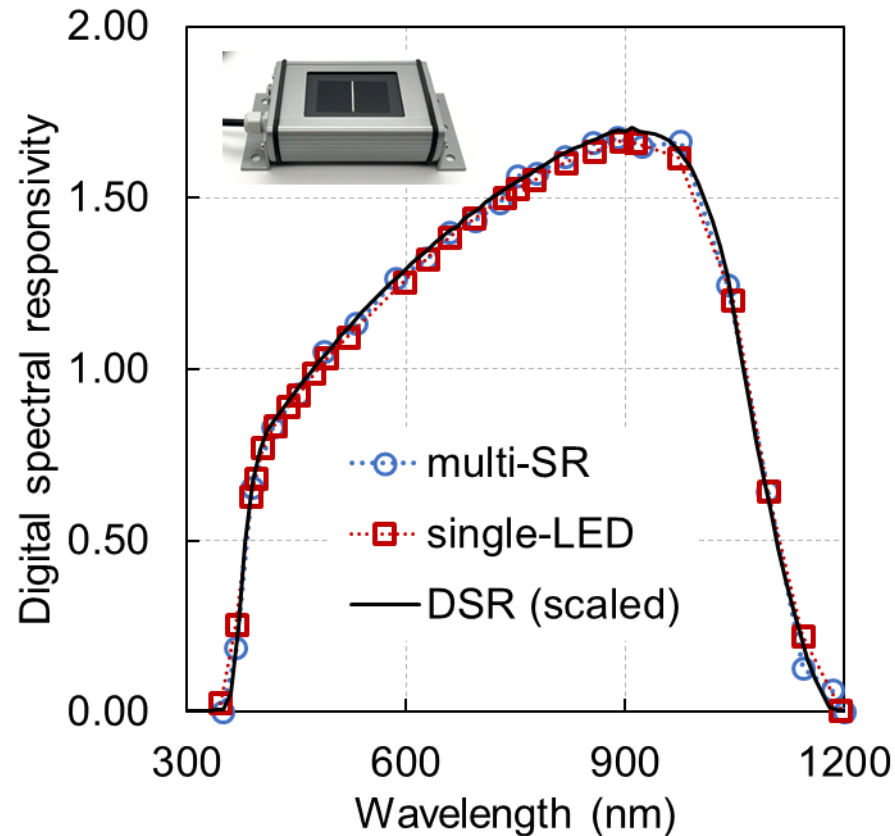
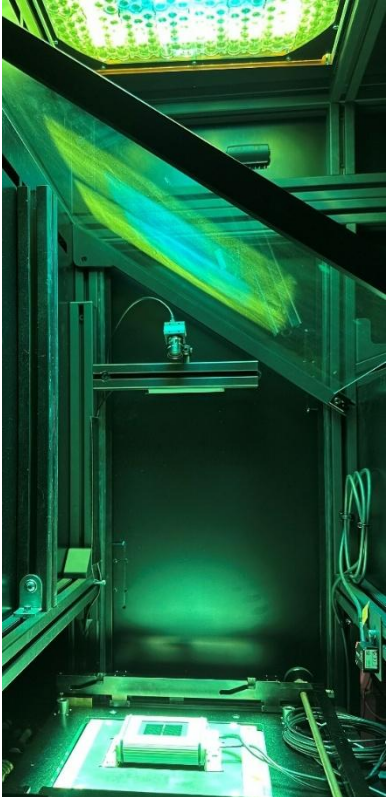

- Introduced two methods for the determination of the spectral responsivity of digital irradiance sensors
- Tests and validation successful!
- Calibration of digital irradiance sensors now available at ISFH CalTeC with a measurement uncertainty of 1.0% (k=2)
- Contact us: sensors@caltec.isfh.de

This work was funded by the **state of Lower Saxony**



and the **project SOLiD-PV** (24GRD04), which has received funding from the **European Partnership on Metrology** (Funder ID: 10.13039/100019599), co-financed from the European Union's Horizon Europe Research and Innovation Programme and by the Participating States.

EUROPEAN PARTNERSHIP



Co-funded by
the European Union

METROLOGY
PARTNERSHIP

